

# On two-bus equivalents of transmission corridors

Costas D. Vournas, *Fellow, IEEE*, Lina Ramirez, *Member, IEEE*, and Ian Dobson, *Fellow, IEEE*

**Abstract**—We derive on a common basis three new and old reductions of a power grid transmission corridor to a two-bus equivalent so that they can be compared and clarified.

**Index Terms**—Circuit analysis, power transmission, power system stability

## I. INTRODUCTION

The increasing number of PMU installations in power systems makes it possible to envisage fast online monitoring systems for various types of stability problems. In cases where the stability boundary is associated, with the power transfer along a specific corridor or interface, this monitoring application can greatly benefit from the existence of a reduced order representation of the system that preserves certain key properties of the actual interface. The REI (Radial Equivalent Independent) equivalent proposed by [1] is well known and in recent literature other reduced representations are proposed by [2], [3], [4]. In this letter, we derive all these reductions to a two-bus equivalent in common framework so that their assumptions and objectives can be explained and compared. In addition, we show a new reduction that preserves the complex powers entering the corridor, which has some similarities to the reduction proposed by [5].

## II. TWO-BUS EQUIVALENTS

There are several approaches to deriving two-bus equivalents that preserve different circuit properties. The equivalents are derived in a four-bus system with two sending buses  $s1$ ,  $s2$ , and two receiving buses  $r1$  and  $r2$  as shown in Fig. 1. Each equivalent gives a different way to combine together quantities to obtain equivalent voltages of the two-bus system. To save space, we reduce a four-bus system, but it is straightforward to generalize the reduction to an  $n$  bus system. For all three equivalents the total complex current entering and leaving the transmission corridor is preserved:

$$I_S = I_{s1} + I_{s2}, \quad I_R = I_{r1} + I_{r2}. \quad (1)$$

On the other hand, the voltages of equivalent sending and receiving buses are selected differently in each equivalent.

### A. REI equivalent

The REI equivalent is an extension of the well-known Ward equivalent [6], [7]. The main idea of the REI equivalent is to transform all loads and generation of the “external network” into an equivalent shunt admittance to ground and then

C.D. Vournas is with School of ECE, National Technical University of Athens, Greece; vournas@power.ece.ntua.gr. L. Ramirez and I. Dobson are with ECPe dept., Iowa State University, Ames IA USA; dobson@iastate.edu. We gratefully acknowledge support in part from the Electric Power Research Center at Iowa State University, and NSF grant CPS- 1135825.

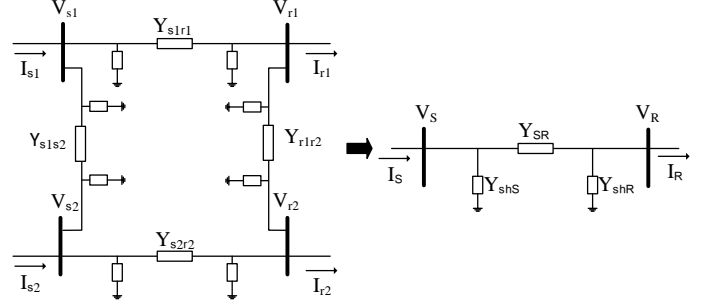

Fig. 1. Example transmission corridor and its reduction to a two-bus equivalent.

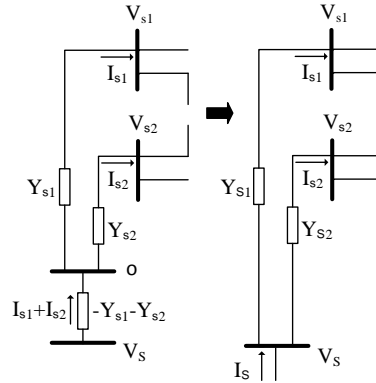

Fig. 2. REI equivalent for the source end; the diagram for the receiving end is similar, but with reversed current directions.

introduce a REI bus connected to the ground bus through an admittance equal to the negative of the sum of shunt admittance. For the corridor shown in Fig. 1, the REI equivalent shown in Fig. 2 is described by the following equations:

$$Y_{si} = \frac{-I_{si}}{V_{si}}, \quad Y_{ri} = \frac{I_{ri}}{V_{ri}} \quad (2)$$

$$V_S = \frac{-I_S}{Y_{s1} + Y_{s2}}, \quad V_R = \frac{I_R}{Y_{r1} + Y_{r2}} \quad (3)$$

Note that by substituting (2) into (3) the REI bus voltage is the harmonic mean of sending (or receiving) voltages weighted by the respective currents.

Since the ground bus O of Fig. 2a cannot be eliminated using Gauss formula (the diagonal element is by definition equal to zero), it has to be substituted as shown in Fig. 2b with an admittance directly connected between the REI sending (or receiving) bus and the individual sending (or receiving) buses, so that all injected currents are maintained in the equivalent:

$$Y_{Si} = \frac{I_{si}}{V_S - V_{si}}, \quad Y_{Ri} = \frac{I_{ri}}{V_{ri} - V_R} \quad (4)$$

The individual buses  $s1$ ,  $s2$ ,  $r1$ ,  $r2$  are eliminated following [7]. The following matrices are introduced ( $Y_{bus}$  is the original 4x4 bus admittance matrix):

$$Y_{SRsr} = \begin{bmatrix} -Y_{S1} & 0 \\ -Y_{S2} & 0 \\ 0 & -Y_{R1} \\ 0 & -Y_{R2} \end{bmatrix}, Y_{22} = \begin{bmatrix} Y_{S1} + Y_{S2} & 0 \\ 0 & Y_{R1} + Y_{R2} \end{bmatrix} \quad (5)$$

$$Y_{sr} = Y_{bus} + \text{diag} [Y_{S1} \quad Y_{S2} \quad Y_{R1} \quad Y_{R2}]. \quad (6)$$

The Kron-reduced 2x2 matrix is

$$Y_{red} = Y_{22} - Y_{SRsr}^T Y_{sr}^{-1} Y_{SRsr}. \quad (7)$$

The admittances of the equivalent system, see Fig. 1, are

$$Y_{SR} = -Y_{red[1,2]} = -Y_{red[2,1]}, \quad (8)$$

$$Y_{shS} = Y_{red[1,1]} + Y_{red[1,2]}, \quad Y_{shR} = Y_{red[2,2]} + Y_{red[2,1]}. \quad (9)$$

### B. Area voltage equivalent

The main idea of the area voltage equivalent [2], [3] is to preserve the admittance of the network “internal” to the corridor so that Ohm’s law  $I_{SR} = Y_{SR}V_{SR}$  is satisfied. The equivalent sending and receiving voltages are obtained as a combination of the voltages of the sending/receiving buses with weights  $w_{siri}$  determined by the admittances. In the ideal case of equal voltage for the sending buses, and equal voltages for the receiving buses, the reduction is exact. For the corridor shown in Fig.1, the voltage across an area equivalent is described by

$$Y_{SR} = Y_{s1r1} + Y_{s2r2}, \quad w_{siri} = \frac{Y_{siri}}{Y_{SR}}$$

$$V_S = w_{s1r1}V_{s1} + w_{s2r2}V_{s2}, \quad V_R = w_{s1r1}V_{r1} + w_{s2r2}V_{r2}$$

### C. Complex power equivalent

This equivalent preserves the total complex power entering and leaving the transmission corridor. For the corridor shown in Fig.1, the complex power equivalent is described by the following equations:

$$S_{si} = V_{si}I_{si}^*, \quad S_{ri} = V_{ri}I_{ri}^* \quad (10)$$

$$S_S = S_{s1} + S_{s2}, \quad S_R = S_{r1} + S_{r2} \quad (11)$$

$$V_S = \frac{S_S}{I_S^*}, \quad V_R = \frac{S_R}{I_R^*} \quad (12)$$

$$Y_{sh} = \frac{I_S - I_R}{V_S + V_R}, \quad Y_{SR} = \frac{I_S - Y_{sh}V_S}{V_S - V_R} \quad (13)$$

Note: A possible variant for both B and C is to define  $V_S$ ,  $V_R$  and then follow the process of (4)-(9).

## III. COMPARISON OF THE THREE EQUIVALENTS

For the system shown in Fig. 1, we develop the three equivalents, and obtain the results in Table I for the reduced voltage magnitudes and angles. The REI equivalent corridor admittance is exact for the cases that the external reduction is required. The power equivalent corridor admittance differs slightly from the REI equivalent corridor admittance because it includes the effect of the shunts only approximately (both

shunts equal), and it does not include the admittances external to the corridor. The larger admittance of the area voltage equivalent is largely due to not accounting for the admittance between sending buses  $s1$ - $s2$  and between receiving buses  $r1$ - $r2$ , which have a non-negligible effect in this example case because the complex voltages are unequal on the same side of the corridor.

TABLE I  
COMPARISON OF THE THREE EQUIVALENTS

Transmission Corridor Data		
$V_{s1} = 1 + j0$	$V_{s2} = 1 - j0.08$	$V_{r1} = 0.91 - j0.15$
$V_{r2} = 0.97 - j0.12$	$I_{s1} = 5.22 - j0.35$	$I_{s2} = 0.97 - j0.45$
$I_{r1} = 4.638 - j3.948$	$I_{r2} = 1.131 - j0.886$	$Y_{s1r1} = 3.8 - j19.1$
$Y_{s2r2} = 11.5 - j57.3$	$Y_{s1s2} = 5.2 - j25.9$	$Y_{r1r2} = 8.2 - j34.8$
$Y_{shs1r1} = j0.362$	$Y_{shr1s1} = j0.362$	$Y_{shs2r2} = j0.933$
$Y_{shr2s2} = j0.933$	$Y_{shs1s2} = j0.173$	$Y_{shs2s1} = j0.173$
$Y_{shr1r2} = j0.623$	$Y_{shr2r1} = j0.623$	

Two-bus Equivalents of Corridor					
Equivalent	$ V_S $	$\delta_S$	$ V_R $	$\delta_R$	$Y_{SR}$
REI	0.997	-0.74	0.93	-9	$6.60 - j41.50$
Area voltage	0.999	-3.27	0.96	-7.68	$15.26 - j74.67$
Complex power	1.003	-0.74	0.929	-9	$5.42 - j42.59$

Angles in degrees, and all other quantities in per unit.

## IV. CONCLUSION

It is advantageous to approximately reduce several lines of a transmission corridor to a single line, which can be applicable in different power system applications such as voltage stability, power markets, and real time monitoring.

The three reductions are preserving different properties of the corridor, and make different approximations. All the equivalents are preserving the current of the complete system. Also, the REI equivalent is preserving the external admittance of the corridor, while the voltage across an area reduction is preserving the internal admittance of the corridor. Furthermore, the complex power equivalent is preserving the complex power. It can be seen that the three equivalents are exactly the same under the condition of equal voltages at the sending buses, and equal voltages at the receiving buses. However when these voltages are not equal the area voltage equivalent can give a significantly different corridor admittance. Since the three reductions preserve different properties, one or other can be better according to the requirements of the application.

## REFERENCES

- [1] P. Dimo, *Nodal Analysis of Power Systems*, Abacus Press, Romania, 1975.
- [2] I. Dobson, “Voltages across an area of a network,” *IEEE Trans. Power Systems*, vol. 27, pp. 993-1002, 2012.
- [3] L. Ramirez, I. Dobson, “Monitoring voltage collapse margin by measuring the area voltage across several transmission lines with synchrophasors,” *IEEE PES General Meeting*, July 2014, National Harbor MD.
- [4] W. Jang, S. Mohapatra, T. J. Overbye, H. Zhu, “Line limit preserving power system equivalent,” *Proc. IEEE Power Energy Conf.*, 2013.
- [5] A. Chakraborty, “A measurement-based framework for dynamic equivalent of large power systems using wide-area phasor measurements,” *IET Generation, Transmission & Distribution*, vol. 2, pp. 68-181, 2011.
- [6] A.B. Almeida, R. Reginatto, R. Jovita, G.C. da Silva, “A software tool for the determination of dynamic equivalents of power systems,” *IREP Symposium*, August 2010, Buzios, Brazil.
- [7] J.B. Ward, “Equivalent circuits for power flow studies,” *AIEE Trans. Power Appl. Syst.*, vol. 68, pp. 373-382, 1949.